



### ORDERING CODE

TYPE	MODEL	VOLTAGE	POWER SUPPLY CONTACTS	RELAY CONTACTS
AT	500	024	E	S

SEE PAGE 60 FOR ORDERING OPTIONS

## Application Example

- Repeated starting attempts of standby generator sets with start failure alarm output.

## Features

- Programmable number of start attempts: 3 to 8.
- Start failure alarm output.
- Separately adjustable starter and pause times.
- Adjustable starter time: 1 to 20 seconds.
- Adjustable pause time: 1 to 20 seconds.
- Power On, Start Relay and Alarm Relay LEDs.
- Microprocessor technology incorporated.
- 5A SPDT Start Relay.
- 5A SPDT Alarm Relay (start failure).

## Description of Operation

The **AT-500** is designed to initiate repetitive starting of standby generator sets. The maximum number of start attempts, the starter (cranking) time and pause times are adjustable.

**Starting:** When power is applied to the AT-500, the Starter relay will energise to initiate the first start attempt. If the power supply of the AT-500 remains uninterrupted, the first start attempt will be followed by a succession of starts with pauses in between. The starter time and paused time can be adjusted independently. If the start attempt is successful, the power supply to the AT-500 should be interrupted as soon as the generator set is running, thus preventing further cranking of the starter motor.

**Start Failure Alarm:** If the generator set fails to start after the set number of attempts, the starter sequence will be terminated and the start failure alarm relay will energise.

**Generator Start-up Detection:** Successful start-up can be detected by:

- Monitoring the output RPM of the generator set with the A-Line AC320 rotational speed monitor,
- Monitoring the output frequency of the generator set with the A-Line AP320 frequency monitor,
- Monitoring the output voltage of the generator set with the A-Line AP220 or AP230 voltage Comparator.

## Operational Diagram

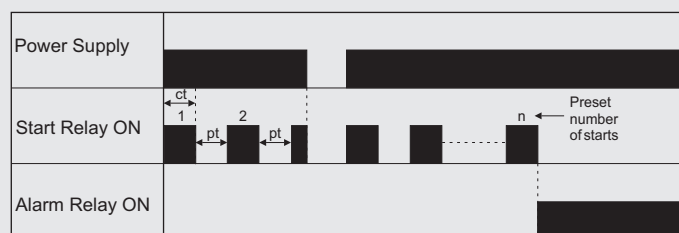

*ct* = cranking time  
*pt* = Pause time



## Description of Controls

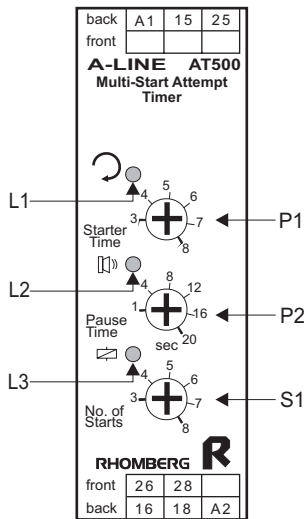

L1: The red “Starter” LED marked illuminates when the starter relay is energised.

L2: The red “Alarm” LED marked illuminates when the starter failure alarm is energised.

L3: The green “Power ON” LED marked illuminates when power is applied to the unit.

S1: The maximum **number of start attempts**, adjustable between 3 and 8 is set on **S1**.

P1: The **Starter time** (i.e. the duration of each start attempt), adjustable from 1 to 20 seconds is set on **P1**.

P2: The **Pause time** between start attempts, adjustable from 1 to 20 seconds is set on **P2**.

## Wiring and Connection

Power Supply	
Phase/ Positive	A1
Neutral/ Negative	A2

Starter Relay	
Normally Open	15 + 18
Normally Closed	15 + 16

Alarm Relay	
Normally Open	25 + 28
Normally Closed	25 + 26

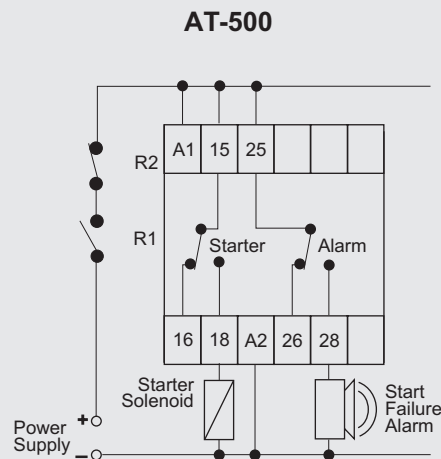

### APPLICATION 1

Typical wiring  
R1 = Mains failure contact, closing when starting is required.  
R2 = Start inhibit contact, opening when the generator set has started (see “Generator start-up detection” in Description of Operation).

## Technical Specifications

POWER SUPPLY			
Type	Voltage	Tolerance	Consumption
AC Transformer (2kV galvanic isolation)	12, 24, 115, 230(220-240), 400(380-415), 525V	±15%	2VA (approx.)
AC Reactive supply	250 (90-250V)	-	2VA
DC Supply	48, 60, 110V	±15%	30mA
AC/ DC supply	12/ 24V	±15%	100mA

START ATTEMPTS	
Number of Start Attempts	3 to 8
Duration of Start Attempts	Adjustable from 1 to 20 seconds
Duration of Pause between start attempts	Adjustable from 1 to 20 seconds

STARTER RELAY	
Contact Rating 250V, 5A	SPDT

ALARM RELAY	
Contact Rating 250V, 5A	SPDT

HOUSING		
Voltage	250V and below	Above 250V
Housing Width	22.5mm	45mm

Additional information in Section J, page 131.